

## QUOTATION/ESTIMATE

CP-61

contact: Christopher Tiessen  
phone: +1 (609) 598-6134  
email: [chris@multiparking.com](mailto:chris@multiparking.com)  
date: 7/17/2024

**Ibrahim Abdel**  
**Vision Design & Development**  
**399 Ridge Rd Suite 6, Dayton, NJ 08810**  
**C: 848-262-8080 | [ibrahimvision79@gmail.com](mailto:ibrahimvision79@gmail.com)**

**Project Name: Islamic Center, New Mosque**

**Address: 216 Ernston Road, Sayreville, NJ 08859**

We hereby like to offer as follows:

Name: CP-61

Space Count: 114

System Type: Stacker

Dimensions: Clear Platform Width of 7'10"

Platform length of 17' 8 ½"

Platform Load Capacity: 6000lbs

Platform type: Fully Hot Dipped Galvanized Trapeze Profile

Corrosion protection: Fully Hot Dipped Galvanized structure, towers

Operation: key switch

Plans Dated: N/A

- Warranty of parts for 1 year
- Shop drawings
- KLAUS Multiparking site review and measurements: Site field measurements must match the KLAUS plans. Any delays due to field conditions may affect pricing.
- Full installation work to be performed in accordance with factory standards.

Required area for unloading of materials and where systems are to be installed:

- Must be clean and free of all debris.
- All construction equipment and personnel of the general contractor, his subcontractors, and all other contractors working on the building project must not be in areas.
- Area where systems to be installed to be available for exclusive use by KLAUS Multiparkings installation team and contractors.

#### EXCLUDED FROM QUOTATION

- Field evaluation by third parties
- Service Contract
- Possible City requirement for a licensed structural engineer's assessment of the adequacy of the system and its supports. A State licensed structural engineer is to provide a letter with their seal that confirms the walls, floors, ceilings, etc. can accept the loads and forces of the various connections (where the KLAUS Multiparking systems connect to the building).
- Custom bracing or extra steel parts necessary to secure installation against seismic or other conditions.
- Walls or fencing required to enclose systems
- Electrical primary service to building / service to systems
- Site preparation, foundations, pits, guardrails, traffic control for unloading equipment, and other non-KLAUS Multiparking work.
- Work noted on the plans to be performed by General Contractor, Buyer, Others.
- Fire protection and requirements by City Fire Department and/or State Authorities.
- Additional Permits - including street permits, etc. and local authorities' special requirements.
- Taxes - Cost of sales tax and other taxes greater than estimate included in proposal
- Tariffs by the US Government. At the time of this quotation no tariffs in place
- Warehousing
- Unexpected Storage Costs due to missing site readiness or lockdown
- Over 40 hours per week, Overtime, Weekend, and Holiday Work
- Additional Days added to projects - due to building construction schedules, City and/or State Requirements, etc.
- All Other Additional Costs: Electrical work, project construction schedule changes, changes from Architect's preliminary plans to final construction documents for project, City or State requirements, etc.

#### WARRANTY

Initial Warranty - 1 Year: All parts

**PAYMENT TERMS (terms are negotiable)**

25% Deposit: Upon Acceptance of Proposal, release for creation of shop drawings, non-refundable  
40% On release for fabrication of supports, equipment  
15% On delivery to site, and to begin mechanical installation  
15% On completion of mechanical installation, and to begin electrical installation and commissioning  
5% Hand-over and acceptance  
Permit Costs: Due 1 week prior to Elevator Contractor preparing documents for submission to City  
Sales Tax: To be paid by customer

**NOTES**

1. Quotation validity until **05/10/23** (for extension please consult Christopher Tiessen, [chris@multiparking.com](mailto:chris@multiparking.com))
2. Any additional work shall only be performed upon signing of a Change Order by Developer / Buyer.

Thank you for the opportunity to submit this quotation. We would appreciate to become your vendor of choice.

KLAUS Multiparking America Inc. is a fully owned subsidiary of KLAUS Multiparking GmbH from Germany and follows the same standards and professional working methods like the Headquarters based on the experience of nearly 60 years designing, manufacturing, and installing worldwide premium mechanical parking solutions.



Benedikt Stellmach

Project Manager



Christopher Tiessen

President & CEO

**ACCEPTANCE OF QUOTATION / ORDER CONFIRMATION**

Date \_\_\_\_\_

Printed Name \_\_\_\_\_

Signature \_\_\_\_\_

Company Name \_\_\_\_\_

Company Address \_\_\_\_\_

## GENERAL TERMS AND CONDITIONS OF SALE AND DELIVERY

These General Terms and Conditions of Sale and Delivery (these "Terms") are applicable to all U.S. customers (the "Customers" and each, individually, a "Customer") of KLAUS Multiparking America Inc., a Delaware corporation (the "Company").

### 1. Terms and Conditions of Sale:

1.1. Company shall sell and deliver to Customer and Customer shall purchase and accept from Company the products (herein, the "Products") described on or in any confirmed order, agreement or quotation, or any combination thereof (the "Order"), pursuant to the terms and conditions of the Order and those specified below, which taken together shall constitute the entire agreement between Company and Customer regarding the Products (herein, this "Agreement").

1.2. No other terms or conditions shall be of any effect unless otherwise specifically agreed to by Company in a separate written agreement duly signed by an officer of Company. Customer will be deemed to have assented to all Terms if any part of the Products is accepted by Customer. If Customer finds any Term not acceptable, Customer must so notify Company at once and must reject the Products delivered under this Agreement. Any additional or different terms or conditions contained in Customer's order or response hereto shall be deemed objected to by Company and shall be of no effect. No general terms and conditions of a Customer shall at any time form a part of the content of any contract or agreement between the Customer and the Company, even if they are not further expressly rejected by the Company.

1.3. Unless otherwise agreed in writing, all quotations for Products are valid for a period of 3 (three) months from the date of issue. Subsequent modifications in quantity or quality, if such are requested by Customer, generally will cause a modification of the quoted price. Drawings and samples enclosed with any quotation remain the property of Company. All drawings and samples shall be treated confidentially by Customer and must be returned to Company after usage.

1.4. No Order is binding upon the Company until the earlier of acceptance of the Order in writing or the delivery of the Products to the Customer. Notwithstanding any prior acceptance of an Order by Company, Company shall have no obligation if the Customer is in breach of any of its obligations hereunder, or any other agreement between the Customer and Company, at the time Company's performance was due.

1.5. All verbal agreements concerning the terms of any Order, including agreements made by telephone, shall have no force and effect unless and until acknowledged by the Company in writing.

1.6. Customer shall bear all costs associated with the cancellation or modification of the Order.

### 2. Prices:

2.1. All price quotations are FCA Works Altrach, Germany (per Incoterms 2020) and do not include costs for packaging, postage or other freight charges, insurance or taxes, if any.

2.2. Products' prices will be governed by the Company's current prices in effect from time to time or by special price quotes made to customer in writing.

2.3. Prices quoted in a currency other than United States Dollars are based on the official exchange rate on the date of the quote. Prices will be invoiced on the basis of the currency exchange rate in effect on the date of confirmation of any Order.

2.4. Company may without notice to Customer increase the price of the Products by the amount of any new or increased tax, duty (excluding franchise, net income and excess profits taxes) or tariff which Company may be required to pay on the manufacture, sale, transportation, delivery, export, import or use of the Products or the materials required for their manufacture or which affects the cost of such materials.

### 3. Terms of Payment:

3.1. Unless otherwise agreed to in writing by the Company, Customer is obliged to pay fifty percent (50%) of the purchase price upon conclusion of the purchase agreement within ten (10) days, an additional thirty percent (30%) within three (3) days upon notification of shipment and the final twenty percent (20%) within ten (10) days upon receipt of final invoice and delivery, whichever occurs earlier.

3.2. Company may without notice change or withdraw extensions of credit at any time. If Company ceases to extend credit terms before shipment, Customer's sole remedy shall be cancellation of its order. If Customer does not receive notice before shipment, its sole remedy shall be rejection of the Products immediately upon delivery.

3.3. If the Customer fails to make payment on or before the date required, Customer shall pay interest to the Company at the rate of fifteen percent (15%) per month or such lesser amount permitted by law. The specification or charging of interest shall not be deemed an agreement to extend credit. Einlagerungskosten ?

3.4. If Customer fails to observe these Terms or the terms of any other agreements between Company and Customer, or if Customer becomes insolvent, all balances then due and owing to the Company shall become due immediately, notwithstanding any agreed upon payment periods. Any Orders that have been confirmed by the Company but not yet filled shall in such cases become cancellable at the sole discretion of Company.

3.5. Customer does not enjoy a right of set-off under any circumstances.

#### 4. Delivery Terms:

4.1. Except as otherwise specified in this Agreement, the Products shall be sold and delivered FCA (per Incoterms 2020) Company's facility in Aitrach; Germany. Title to and risk of loss for the Products shall pass to Customer upon delivery thereof to any common carrier at such facility.

4.2. Any agreed Delivery Period commences on the day on which any Order and accompanying documents, such as drawings, have been clarified by the Company, but in any event no earlier than the written acceptance of any Order by the Company. Sales which extend over a certain period of time, and where quantities have not been fixed in advance, shall be subject to separate agreements concerning the quantity and delivery period regarding each separate sales transaction and/or request for delivery made by a Customer. Delivery Periods determine the date of dispatch ex works. All delivery dates are approximate; time shall not be of the essence.

4.3. Customer will be billed for and shall pay all freight, transportation, shipping, insurance and handling charges, duties, and taxes, including any applicable VAT, sales, personal property, ad valorem, and other taxes, duties, levies or charges imposed by any governmental authority, irrespective of whether applicable law makes such items the responsibility of the buyer or seller, but excluding any taxes payable by Company with respect to its net income.

4.4. Customer, shall, subject to Company's available facilities at the shipping point, determine the type of transportation and shall notify Company thereof at the time Customer places each Order. If Customer shall fail to so notify Company, Company or its agent may select any commercial air, ship, motor or rail carrier or any combination thereof for the transportation of the Products. Company will make deliveries of the Products in the quantities ordered as near as reasonably possible to Customer's requested delivery dates.

4.5. Company shall use its reasonable efforts to deliver the Products to Customer by the agreed upon date. However, except in cases of Company's willful misconduct or gross negligence, Company shall not be liable to Customer for delays in delivery or damage to Products while in transit, irrespective of whether Company or Customer determined the mode of transportation.

4.6. In cases of deliveries of Products manufactured to Customer's specification ("Special Orders"), Company reserves the right to rely on the technical specifications provided by Customer.

4.7. Unless otherwise agreed to in writing, all tools, models, plans, blueprints or other devices and/or documents used and/or developed by Company (the "Tools") in order to fulfill any Order or Special Order are the property of the Company, even if the cost of development and/or manufacturing of such tools, models, plans, blueprints or other devices and/or documents was wholly or partially borne by the Customer.

#### 5. Security Interest:

5.1. As security for the timely payment and performance of all Customer's indebtedness to Company, Customer hereby grants to Lender a first priority security interest in the Products following delivery thereof to Customer ("Collateral"). Such Interest shall remain in force until payment in full of the entire purchase price for the Products and any other amounts due to the Company by Customer.

5.2. If so requested by Company, the Customer shall deliver to Company, in form and substance satisfactory to Company, and duly executed as required by Company, financing statements and other security interest perfection documentation in form and substance satisfactory to Company, duly filed under the UCC in all jurisdictions as may be necessary, or in Company's opinion, desirable, to perfect Company's security interest and lien in the Collateral, in order to establish, perfect, preserve and protect Company's security interest as a legal, valid and enforceable security interest and lien, and all property or documents of title, in cases in which possession is required for the perfection of Company's security interest.

**6. Limitation of Liability:**

6.1. UNDER NO CIRCUMSTANCES SHALL COMPANY BE LIABLE FOR ANY PUNITIVE, INDIRECT, INCIDENTAL, SPECIAL OR CONSEQUENTIAL DAMAGES, INCLUDING BUT NOT LIMITED TO, DAMAGES FOR LOSS OF EARNINGS, PROFITS, REVENUE, GOODWILL OR USE, INCURRED BY CUSTOMER OR ANY THIRD PARTY, WHETHER IN AN ACTION BASED UPON EQUITY, CONTRACT, TORT, STRICT LIABILITY, OR IMPOSED BY CASE LAW OR STATUTE, OR OTHERWISE, EVEN IF PREVIOUSLY ADVISED OF THE POSSIBILITY OF SUCH DAMAGES.

6.2. NOTWITHSTANDING THE TERMS AND CONDITIONS SET FORTH IN SECTION 6.1., COMPANY'S LIABILITY – WHETHER BASED UPON CONTRACT, TORT, EQUITY, NEGLIGENCE OR ANY OTHER LEGAL CONCEPT – SHALL IN NO EVENT EXCEED THE VALUE OF CUSTOMER'S ORDER TO WHICH THE DAMAGES ARE PERTAINING TO, AS DESCRIBED ON THE ORDER FORM, OR THE ORDER VALUE FOR ONE (1) CALENDAR YEAR, WHICHEVER AMOUNT IS LOWER. IT IS AGREED AND ACKNOWLEDGED THAT THE PROVISIONS OF THIS AGREEMENT ALLOCATE THE RISKS BETWEEN COMPANY AND CUSTOMER IN AN EQUITABLE MANNER, THAT COMPANY'S PRICING REFLECTS THIS ALLOCATION OF RISK, AND BUT FOR THIS ALLOCATION AND LIMITATION OF LIABILITY, COMPANY WOULD NOT HAVE ENTERED INTO THIS AGREEMENT.

6.3. IN JURISDICTIONS THAT LIMIT THE SCOPE OF OR PRECLUDE LIMITATIONS OR EXCLUSION OF REMEDIES OR DAMAGES, OR OF LIABILITY, SUCH AS LIABILITY FOR GROSS NEGLIGENCE OR WILLFUL MISCONDUCT OR DO NOT ALLOW IMPLIED WARRANTIES TO BE EXCLUDED, THE LIMITATION OR EXCLUSION OF WARRANTIES, REMEDIES, DAMAGES OR LIABILITY SET FORTH ABOVE ARE INTENDED TO APPLY TO THE MAXIMUM EXTENT PERMITTED BY APPLICABLE LAW. CUSTOMER MAY ALSO HAVE OTHER RIGHTS THAT VARY BY STATE, COUNTRY OR OTHER JURISDICTION.

**7. Force Majeure:**

7.1. Company shall not be liable to Customer or any other person for any failure or delay in the performance of any obligation under this Agreement due to events beyond its reasonable control, including, but not limited to, fire, storm, flood, earthquake, explosion, accident, acts of the public enemy, wars, riots and public disorder, sabotage, strikes, lockouts, labour disputes, labour shortages, work slowdown, stoppages or delays, shortages or failures or delays of energy, materials, supplies or equipment, transportation embargoes or delays, acts of God, breakdown in machinery or equipment, and, except as otherwise set forth in this Agreement, acts or regulations or priorities of the federal, state or local governments.

7.2. Customer shall not be liable to Company or any other person for any failure or delay in the performance of any obligation under this Agreement due to events beyond its reasonable control, including, but not limited to, fire, storm, flood, earthquake, explosion, accident, acts of the public enemy, wars, riots and public disorder, sabotage, strikes, lockouts, labour disputes, labour shortages, work slowdown, stoppages or delays, shortages or failures or delays of energy, materials, supplies or equipment, transportation embargoes or delays, acts of God, breakdown in machinery or equipment, and, except as otherwise set forth in this Agreement, acts or regulations or priorities of the federal, state or local governments.

7.3. When the event operating to excuse performance by either party shall cease, this Agreement shall continue in full force until all deliveries have been completed.

**8. Insurance:**

8.1. Customer shall pay for and maintain a comprehensive general liability insurance, including insurance coverage for premises operations, independent contractors, completed operations, contractual liability, personal injury liability, property damage (broad form), bodily injury (occurrence in lieu of accident coverage) in the following amounts:

Liability Insurance -- \$2,000,000/total liability coverage; \$1,000,000/each occurrence  
Personal Injury -- \$2,000,000/total liability coverage; \$1,000,000/each occurrence  
Property Damage -- \$2,000,000/total liability coverage; \$1,000,000/each occurrence

8.2. Any insurance policy required to be maintained hereunder by the Customer shall provide that Company shall be notified in writing within thirty (30) days of the effective date of any change in or cancellation of such policy. The Customer shall, before delivery of the Product, deliver to the Company Certificates of Insurance, in form and substance satisfactory to the Company, indicating that the Customer is in compliance with the insurance requirements set forth herein. The Customer shall provide the aforesaid insurance insuring the Products, the Company, and their agents and employees by obtaining a protective liability insurance policy designating the Company and its agents and employees as the additional insured.

**9. Miscellaneous Terms:**

9.1. Any controversy or claim arising out of or relating to this Agreement, or the negotiation or breach thereof, shall be exclusively settled by arbitration in accordance with the International Arbitration Rules of the American Arbitration Association ("AAA"). The award shall be final and binding. Judgment upon the award rendered by the arbitrator or the arbitrators may be entered in any court having jurisdiction thereof. The arbitration shall be held in New York, New York, shall be conducted in the English language, and shall be conducted (i) if the amount in dispute is less than two hundred fifty thousand U.S. Dollars (\$250,000), before a single arbitrator mutually agreeable to Company and Customer, or if no agreement can be reached, then selected by the AAA, or (ii) if the amount in dispute is two hundred fifty thousand U.S. Dollars (\$250,000) or more, before three (3) arbitrators. The arbitrator(s) shall make detailed findings of fact and law in writing in support of his, her or their decision, and shall award reimbursement of attorney's fees and other costs of arbitration to the prevailing party, in such manner as the arbitrator shall deem appropriate. In addition, the losing party shall reimburse the prevailing party for reasonable attorneys' fees and disbursements, the costs of the arbitration (including but not limited to the fees and expenses of the arbitrator and expert witnesses) and the costs incurred by the prevailing party in successfully seeking any preliminary equitable relief or judicially enforcing any arbitration award.

9.2. This Agreement shall be governed by and construed in accordance with the law of the State of New York, without giving effect to principles of conflict of laws.

9.3. If any provision contained in this Agreement is held to be invalid, illegal or unenforceable, such invalid, illegal or unenforceable provision shall be severed from the remainder of this Agreement, and the remainder of this Agreement shall be enforced. In addition, the invalid, illegal or unenforceable provision shall be deemed to be automatically modified, and, as so modified, to be included in this Agreement, such modification being made to the minimum extent necessary to render the provision valid, legal and enforceable. Notwithstanding the foregoing, however, if the severed or modified provision concerns all or a portion of the essential consideration to be delivered under this Agreement by one party to the other, the remaining provisions of this Agreement shall also be modified to the extent necessary to equitably adjust the parties' respective rights and obligations hereunder.

9.4. In the event of a violation or threatened violation of Company's proprietary rights, Company shall have the right, in addition to such other remedies as may be available pursuant to law or this Agreement, to temporary or permanent injunctive relief enjoining such act or threatened act. The parties acknowledge and agree that legal remedies for such violations or threatened violations are inadequate and that Company would suffer irreparable harm.

9.5. The parties hereto are independent contractors and nothing in this Agreement will be construed as creating a joint venture, employment or agency relationship between the parties.

This Agreement, including any Schedules attached hereto, contains the entire agreement of the parties with respect to the subject matter of this Agreement, and supersedes all prior agreements between them, whether oral or written, of any nature whatsoever with respect to the subject matter hereof. This Agreement is binding upon the parties hereto, their successors and permitted assigns.

\*\*\*\*\*



# Product data

Dimensions, technical information and performance specification

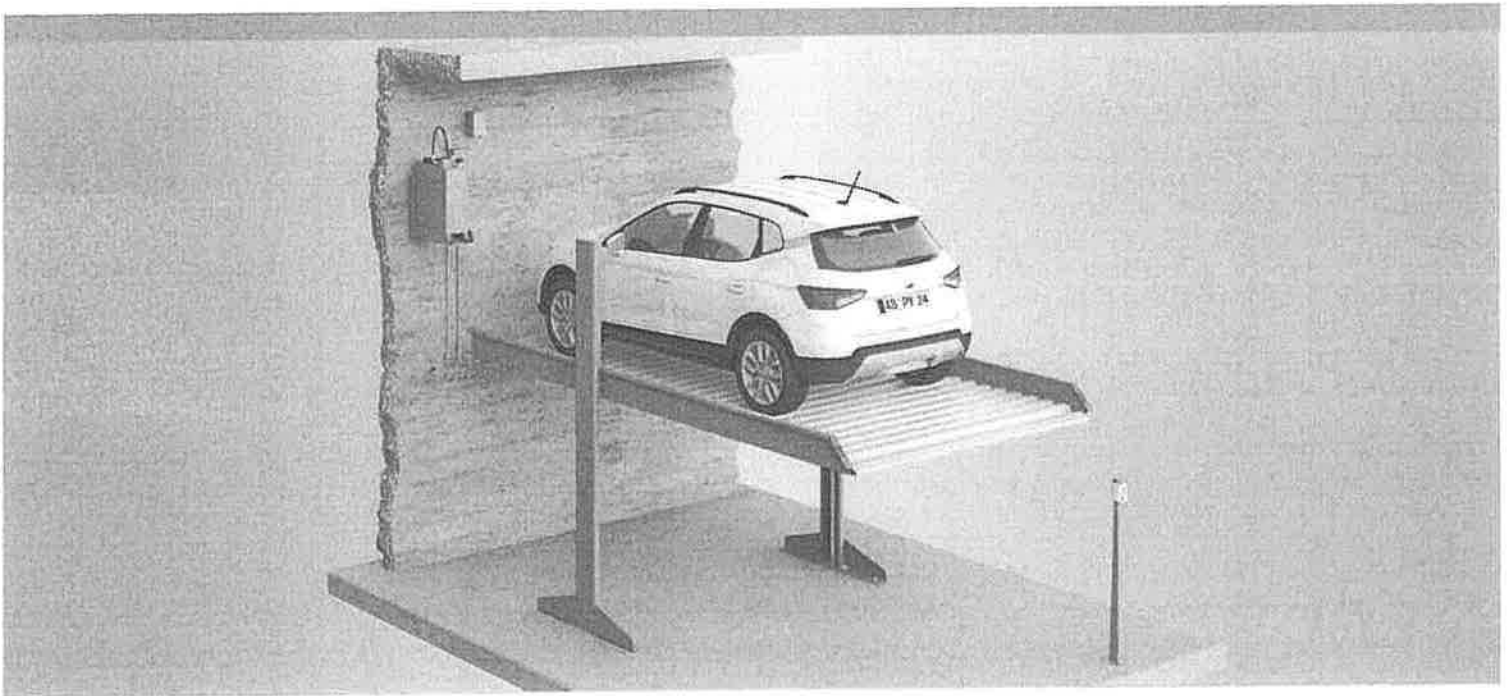

## spacevario CP61

---



## Table of contents

Explanation of symbols.....	2	Loading schedule & strutting.....	7
Parking positions.....	2	Access incline.....	8
Dimensions and tolerances.....	2	Clearance for installations.....	8
Overview of building configuration.....	3	Electrical installation.....	9
Vehicle data.....	3	Technical information.....	10
Overview of system types and ceiling heights.....	4	Performance specification.....	11
Width dimensions.....	5	Services to be provided by the customer.....	12
Width dimension with door.....	5	Subject to technical changes.....	12
Width dimension without door.....	6		

## Explanation of symbols



Platforms accessible horizontally.



max. load per parking space in kg.



The systems provided are consistent with DIN EN 14010 and the EC Machinery Directive 2006/42/EC. This system has also undergone a voluntary compliance test conducted by TÜV SÜD.

## Parking positions

### Lower parking space

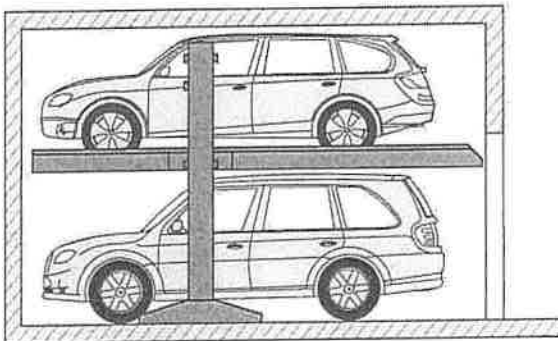

The lower vehicle can park in or leave the parking space.

### Upper parking space

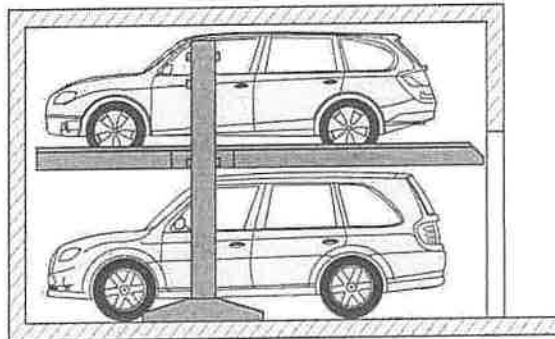

The upper vehicle can park in or leave the parking space.

## Dimensions and tolerances



All dimensions and minimum final dimensions.

Tolerance for dimensions +3/-0. Dimensions in cm.

In order to adhere to the minimum final dimensions, the tolerances in accordance with the German Construction Tendering and Contract Regulations [VOB], Part C (DIN 18330 and 18331) and DIN 18202 must also be taken into account.

## Overview of building configuration

### Building configuration without door

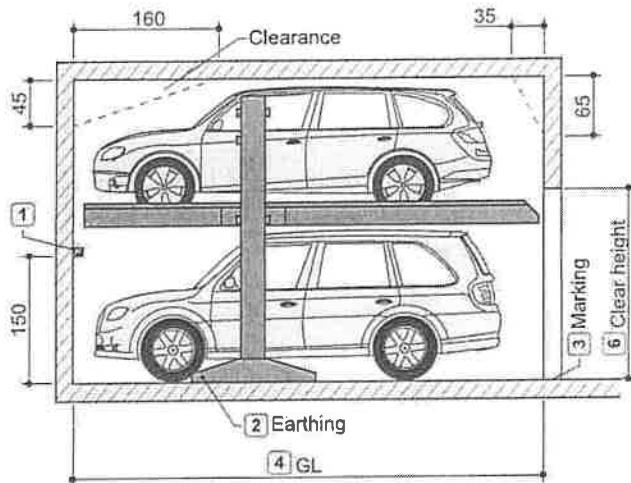

- 1 With dividing walls: Wall opening 10 x 10 cm.
- 2 Equipotential bonding from foundation earth connection to system (to be provided by the customer).
- 3 In accordance with DIN EN 14010, the customer must provide 10 cm wide, yellow/black marking in accordance with DIN ISO 3864, in the access area in front of the contact area of the upper platform edge to identify the hazard area. (see "Loading schedule & strutting", page 7).

### Building configuration with door

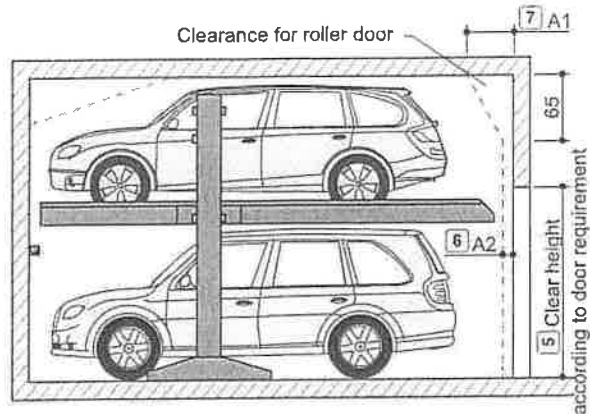

- 4 GL = building length
  - 520 cm for vehicles up to 5.0 m long
  - Shorter versions are possible on request - observe local regulations on parking space lengths.
- 5 Clear height in accordance with local regulations. Maximum vehicle height + 10 cm.
- 6 Dimensions A1 and A2 must be coordinated between the door manufacturer and the customer.



The lower vehicle must exit before the platform is lowered.

## Vehicle data

### Version

SP (single platform) = 2 vehicles

### Parking options

Series vehicles:  
saloon, estate, SUV, van in accordance with clearance gauge and maximum parking space load.

	SP
Weight	2600 kg
Wheel load	650 kg

- 1 Vehicle height (see "Overview of system types and ceiling heights", page 4)
- 2 Vehicle length (see "Overview of building configuration", page 3)

### Clearance gauge

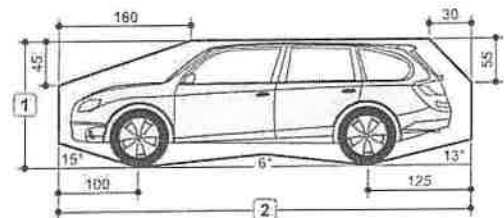

Vehicle width 190 cm with platform width 230 cm.  
Correspondingly wider vehicles can be parked with wider platforms.

## Overview of system types and ceiling heights

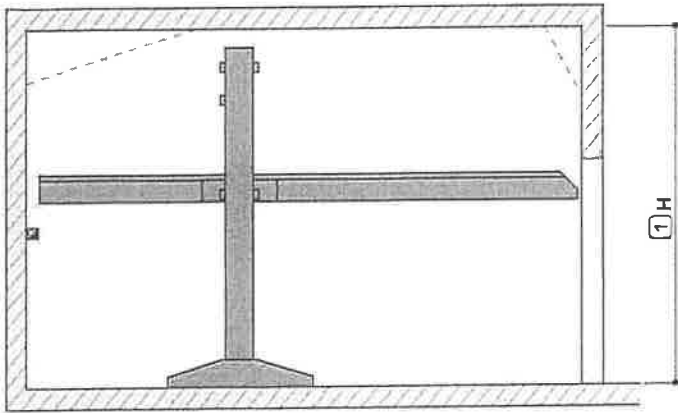

H: Ceiling height

1 If the ceiling is higher, correspondingly higher vehicles can be parked on the top.

Type	Vehicle height, lower	Vehicle height, upper													
		150	155	160	165	170	175	180	185	190	195	200	205	210	215
CP61-160	150	320	325	330	335	340	345	350	355	360	365	370	375	380	385
CP61-170	160	330	335	340	345	350	355	360	365	370	375	380	385	390	395
CP61-180	170	340	345	350	355	360	365	370	375	380	385	390	395	400	405
CP61-190	180	350	355	360	365	370	375	380	385	390	395	400	405	410	415
CP61-200	190	360	365	370	375	380	385	390	395	400	405	410	415	420	425
CP61-210	200	370	375	380	385	390	395	400	405	410	415	420	425	430	435

H - Ceiling height

### Example configuration



Example: Vehicle height, lower 170 cm and vehicle height, upper 190 cm.

Type: CP61-180

Ceiling height: 380 cm

Type	Vehicle height, lower	Vehicle height, upper													
		150	155	160	165	170	175	180	185	190	195	200	205	210	215
CP61-160	150	320	325	330	335	340	345	350	355	360	365	370	375	380	385
CP61-170	160	330	335	340	345	350	355	360	365	370	375	380	385	390	395
CP61-180	170	340	345	350	355	360	365	370	375	380	385	390	395	400	405
CP61-190	180	350	355	360	365	370	375	380	385	390	395	400	405	410	415

H

## Width dimensions



We recommend platform widths of minimum 250 cm and driving lane widths of 650 cm in order that vehicles can comfortably access the Multiparking system and enter and leave without difficulty.

Narrower platforms may impede parking according to the following criteria.

- Driving lane width
- Entrance conditions
- Vehicle dimensions

- 1 Observe minimum driving lane width in accordance with local regulations.

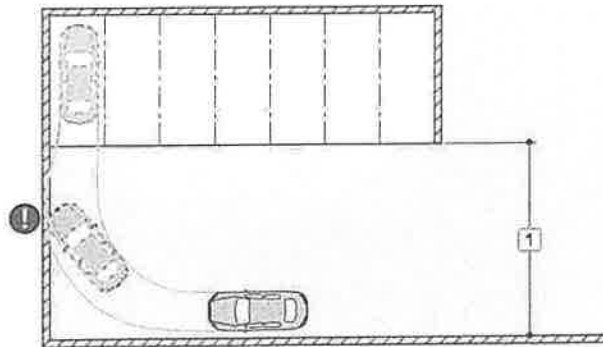

### Width dimension with door

	Single platform - SP 3		Double arrangement - 2x SP 3	
Support outside of the system area				
	Clear platform width 2	Passage width B6	Clear platform width 2	Passage width B6
SP	230	230	2x SP	490
	240	240		510
	250	250		530
	260	260		550
	270	270		570

- 1 Door section (dimension A3 must be agreed on-site with the door manufacturer). With lateral closing doors, coordination between the door manufacturer and KLAUS Multiparking is required.
- 2 Narrower platform widths are available on request - although it should be noted that use of the parking space will be limited by the reduced width and parking will be made more difficult. In many cases, these are not considered demonstrable vehicle parking spaces - observe local regulations.
- 3 If seismic loading is likely, special width dimensions apply. Please contact KLAUS Multiparking for planning documents.

**Width dimension without door**

	Single platform - SP <sup>2</sup>	Double arrangement - 2x SP <sup>2</sup>	Triple arrangement - 3x SP <sup>2</sup>			
Dividing walls						
Support in the system area						
Support outside of the system area						
	Clear platform width <sup>1</sup>	Dividing walls B1	Support in the system area B2      B3		Support outside of the system area B4      B5	
SP	230	260	255	245	250	240
	240	270	265	255	260	250
	250	280	275	265	270	260
	260	290	285	275	280	270
	270	300	295	285	290	280
2x SP	230	520	515	510	510	500
	240	540	535	530	530	520
	250	560	555	550	550	540
	260	580	575	570	570	560
	270	600	595	590	590	580
3x SP	230	780	775	770	770	760
	240	810	805	800	800	790
	250	840	835	830	830	820
	260	870	865	860	860	850
	270	900	895	890	890	880

- <sup>1</sup> Narrower platform widths are available on request - although it should be noted that use of the parking space will be limited by the reduced width and parking will be made more difficult. In many cases, these are not considered demonstrable vehicle parking spaces - observe local regulations.
- <sup>2</sup> If seismic loading is unlikely, special width dimensions apply. Please contact KLAUS Multiparking for planning documents.

## Loading schedule & strutting



The systems are dowelled into the ground. The drill hole depth in the floor plate is approx. 15 cm, in the walls approx. 12 cm.  
The floor plate and walls must be from concrete (quality min. C20/25).  
The dimensions for the bearing points have been rounded. If the precise figures are required, please consult KLAUS Multiparking.

Various options are available for the strutting depending on the structural conditions.

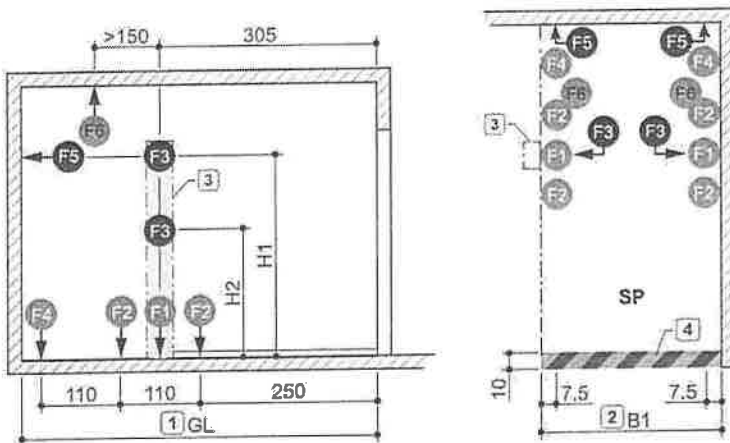
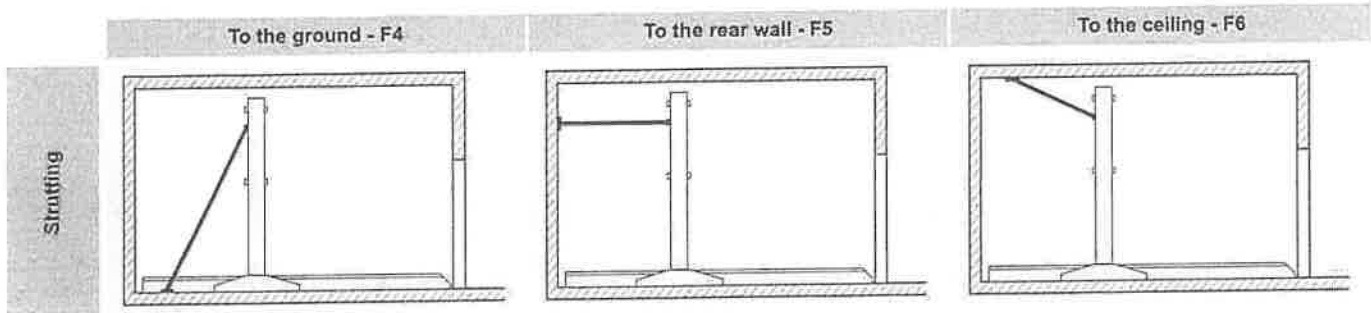

Parking space load	F1	F2	F3	F4	F5	F6
2600 kg	+ 30,0 kN	- 4,2 kN	- 1,8 kN	- 12 kN	- 6.9 kN	- 8.2 kN

	Type					
	CP61-160	CP61-170	CP61-180	CP61-190	CP61-200	CP61-210
H1	290	290	290	320	320	320
H2	185	185	185	215	215	215

- ① GL = building length
- ② Width dimension B1 (see "Width dimension without door", page 6)
- ③ The system must be supported on both sides. An additional stand may be installed if there are no walls at the sides. A floor area of 50 x 30 cm is required for these stands (concrete quality min. C20/25, drill hole depth approx. 15 cm).
- ④ Marking in accordance with DIN ISO 3864 (illustration colour not consistent with DIN ISO 3864)

## Access incline



The maximum access inclines specified in the symbol sketch must not be exceeded. Improper configuration can lead to extreme difficulty accessing the system, for which KLAUS Multiparking cannot be held liable.

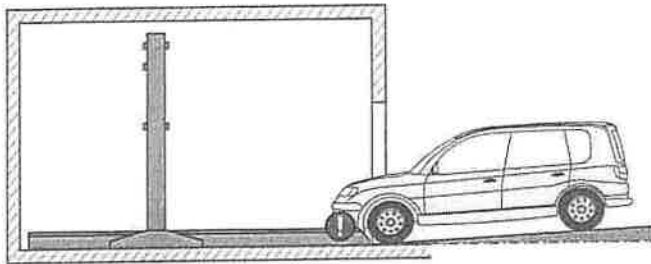

max. 4% slope

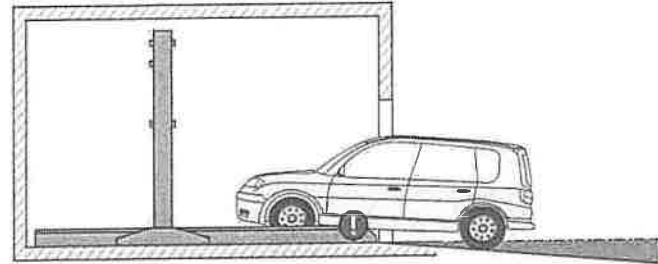

max. 14% gradient

## Clearance for installations



These clearances apply to vehicles parked forwards only, with exit on the left. The clearances must be adjusted for vehicles with exit on the right or parked in reverse.

These clearances apply where struts to the ground are used. For other variants, the clearances must be redesigned accordingly.

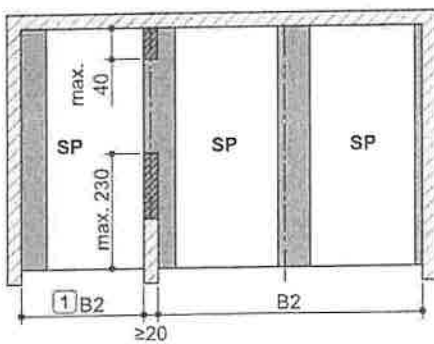
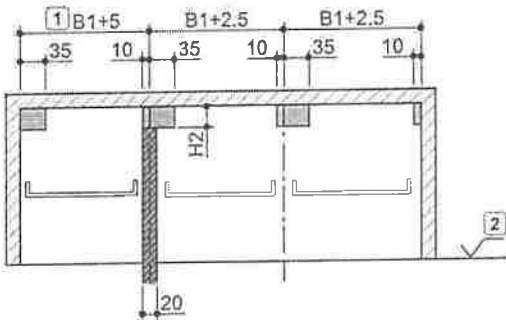

max. Vehicle height, upper	Type		
	CP61-160 CP61-190	CP61-170 CP61-200	CP61-180 CP61-210
150	0	10	20
155	5	15	25
160	10	20	30
165	15	25	35
170	20	30	40
175	25	35	45
180	30	40	50
185	35	45	55
190	40	50	60
195	45	55	65
200	50	60	70
205	55	65	75
210	60	70	80
215	65	75	85

1 Maße B1 und B2 (see "Width dimension with door", page 5, "Width dimension without door", page 6)

2 Entrance level

Clearance for lengthways cable routing

Clearance for vertical pipes, air ducts, etc.



## Electrical installation

### Electrical installation diagram

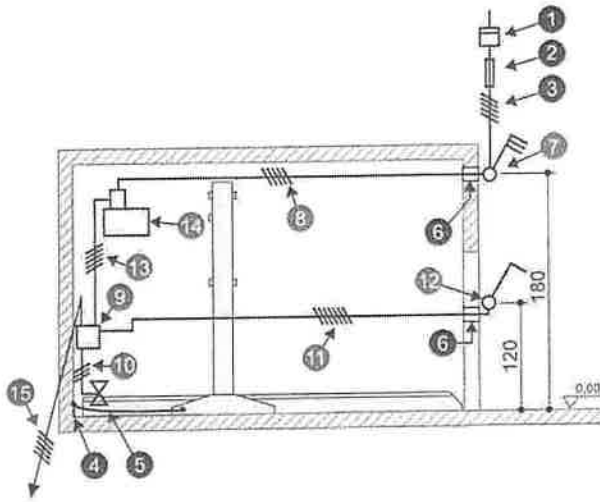

### On-site facilities for operating element

#### Surface-mounted operating element

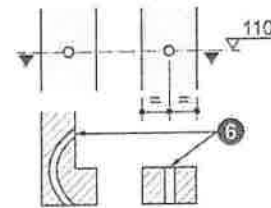

### Electrical specifications (services to be provided by the customer)

Nr.	Quantity	Designation	Position	Frequency
1	1	Power meter	In the supply cable	
2	1	Pre-fuse: 3x safety fuse 16 A (slow-blow) or Circuit breaker 3x 16 A (trip characteristic K or C)	in the supply cable	1x per unit
3	1	Supply cable 5 x 2.5 mm <sup>2</sup> (3 PH+N+PE) with marked wires and protective earth	to master switch	1x per unit
4	every 10 m	Foundation earth connection	Rear wall corner of the building	
5	1	Equipotential bonding in accordance with DIN EN 60204 from foundation earth connection to system		1x per system
6	2	Empty pipe EN 25 (M25)		

### Electrical specifications (KLAUS Multiparking scope of supply)

Nr.	Designation
7	Lockable master switch
8	Supply cable 5 x 2.5 mm <sup>2</sup> (3 PH+N+PE) with marked wires and protective earth
9	Unit junction box
10	Control cable 3 x 0.75 mm <sup>2</sup> (PH+N+PE)
11	Control cable 7 x 1.5 mm <sup>2</sup> with marked wires and protective earth
12	Operating element
13	Control cable 5 x 1.5 mm <sup>2</sup> with marked wires and protective earth
14	Hydraulic unit 3 kW, three-phase current 230/400 V / 50 Hz
15	Control cable 5 x 1.5 mm <sup>2</sup> with marked wires and protective earth to next system

## Technical information

### Usage area

The system is suitable for a fixed group of users as standard. Where users change - in the upper parking spaces only - (e.g. short-term parking in office buildings or hotels), structural modifications to the Multiparking system are required. Please request a consultation if required.

### Units

Low-noise, bearing-mounted hydraulic units are installed on rubber-metal blocks. Consequently, we recommend separating the garage body from the residential building.

### Ambient conditions

Ambient conditions for the areas around Multiparking systems: Temperature range  $-10$  to  $+40^{\circ}$  C. Relative humidity 50 % to a maximum external temperature of  $+40^{\circ}$  C. If ascent/descent times are specified, these relate to an ambient temperature of  $+10^{\circ}$  C and with the system positioned immediately adjacent to the hydraulic unit. These times are increased at lower temperatures or with longer hydraulic lines.

### Seismic conditions

Local seismic conditions may require special precautions such as strutting. Please contact KLAUS Multiparking for seismic reports and advice.

### Building application documents

Multiparking systems generally require approval. Please observe local regulations and stipulations.

### Care

To prevent corrosion damage, please observe our special cleaning and care instructions and ensure that your garage is well ventilated.

### Corrosion protection

Our coating system was designed in accordance with DIN EN ISO 12944-5 Appendix A, Paint systems for corrosivity category C3. The powder coating was checked in accordance with DIN EN ISO 12944-6 and compliance with the requirements verified in test series. Zinc coatings are in accordance with DIN EN ISO 1461 and DIN EN 10346.

### Rallings

If there are roadways immediately adjacent to or behind the systems, the customer must provide barriers in accordance with DIN EN ISO 13857. This also applies during the construction stage.

### CE conformity

The systems provided are consistent with DIN EN 14010 and the EC Machinery Directive 2006/42/EC. This system has also undergone a voluntary compliance test conducted by TÜV SÜD.

### Noise protection

#### Standard noise protection:

In accordance with DIN 4109-1 Noise protection in high-rise - Section 9: Maximum sound pressure level in living and sleeping areas 30 dB (A). User noise is not subject to the requirements.

The following dimensions are required for adherence to this value:

- Noise protection package in accordance with quote/order (KLAUS Multiparking)
- Sound insulation dimension of the building structure of min.  $R'w = 57$  dB (service to be provided by the customer)

#### Increased sound protection (special agreement):

In accordance with DIN 4109-5 Increased noise protection in high-rise - Section 8:

Maximum sound pressure level in living and sleeping areas 25 dB (A). User noise is not subject to the requirements.

The following dimensions are required for adherence to this value:

- Noise protection package in accordance with quote/order (KLAUS Multiparking)
- Sound insulation dimension of the building structure of min.  $R'w = 62$  dB (service to be provided by the customer)

#### Note:

User noise is noise that can be influenced individually by the user of our Multiparking systems. This includes, e.g., accessing the platform, the slamming of vehicle doors, engine and brake noise.

## Performance specification

### Description

Multiparking system for dependent parking of 2 vehicles one on top of the other. The lower vehicle parks directly on the floor plate. The lower vehicle must exit before the platform is lowered.

Upweighting to 2600 kg is subsequently possible.

Dimensions in accordance with the underlying building, width and height dimensions.

Access to the parking spaces horizontally (installation tolerance  $\pm 1\%$ ).

Vehicle positioning in the upper parking space by positioning aid mounted on one side (to be adjusted in accordance with the operating instructions).

Control via an operating element with automatic reset by means of simultaneous key.

Operating element usually installed in front of the support or on the outside of the door reveal.

Concise instructions at each operating point.

Special dimensions must be observed in buildings with door.

### Multiparking system comprising:

- 2 columns with column bases secured to the floor
- 2 sliders (with sliding guides secured to the columns)
- 1 platform
- 1 mechanical synchronisation system (for synchronised operation of the hydraulic cylinders when lifting and lowering)
- 1 hydraulic cylinder
- Dowels, screws, connectors, bolts, etc.
- The platforms/parking spaces are continuously accessible.

### Platform comprising:

- Platform profiles
- Adjustable positioning aid
- Chamfered ramp
- Side beams
- Screws, nuts, washers, spacers, etc.

### Hydraulic system comprising:

- Hydraulic cylinders
- Magnetic valves
- Hydraulic lines
- Bolted connections
- High-pressure hoses
- Attachments

### Electrical system comprising:

- Operating element (emergency-stop, key, 1 simultaneous key per parking space)
- Junction box on wall valve
- Electrical locking

### Hydraulic unit comprising:

- Hydraulic unit (low-noise, fitted to bracket and bearing mounted on rubber-metal block)
- Hydraulic oil tank
- Oil filling
- Internal gear pump
- Pump holder
- Coupling
- Three-phase motor
- Circuit protection (with thermal overload relay and control fuse)
- Test pressure gauge
- Pressure relief valve
- Hydraulic hoses (to attenuate noise transmission to the hydraulic pipes)

## Services to be provided by the customer

### Barriers

Barriers that may be required in accordance with DIN EN ISO 13857 where there are roadways immediately in front of, adjacent to or behind the systems. This also applies during the construction stage.

### Parking space numbering

Parking space numbering, if required.

### Building services systems

Any lighting, ventilation, fire-extinguishing and fire-alarm systems that may be required, plus clarification and compliance with corresponding official documentation.

### Lighting

The customer must observe local regulations pertaining to the illumination of parking spaces and roadways. In accordance with DIN EN 12464-1 'Light and lighting - Lighting of work places', an illumination level of min. 200 lx is recommended for the parking spaces and operating area of the system.

### Warning marking

In accordance with DIN EN 14010, the customer must provide 10 cm wide, yellow/black marking in accordance with DIN ISO 3864, in the access area in front of the contact area of the upper platform edge to identify the hazard area.

### Wall openings

Any wall openings that may be required should be in accordance with the sectional drawings (see "Overview of building configuration", page 3).

### Supply cable to master switch - foundation earth

The customer must lay the supply cable to the master switch during assembly. Functional capability can be checked by our engineers on site, in conjunction with the electronics engineer. If this is not possible during assembly for reasons attributable to the customer, the customer must commission an electronics engineer.

The customer must earth the steel structure with a foundation earth connection (earthing distance max. 10 m) and equipotential bonding in accordance with DIN EN 60204.

### Operating element

Empty conduits and recesses for the operating element (see "Electrical installation", page 9). Consultation with KLAUS Multiparking is required when using folding doors.

## Subject to technical changes

In the course of technical progress, KLAUS Multiparking shall be entitled to use newer or different technologies, systems, processes or standards to provide the services than initially offered, provided that this does not disadvantage the customer in any way.

Manufacturer:

**KLAUS Multiparking systems pvt. ltd**

NKB House  
Survey No.98, Plot No.14  
Bhusari Colony, Pune 41 1038

+91 20 6681 5800/1

sales@klausmultiparking.in  
klausindia.com

Sales office: